

© COPYRIGHT OF THIS DRAWING IS RESERVED BY DBFL CONSULTING ENGINEERS. NO PART SHALL BE REPRODUCED OR TRANSMITTED WITHOUT THEIR WRITTEN PERMISSION.

NO CHANGES OF WHATSOEVER NATURE ARE TO BE MADE TO ANY DETAILS SET OUT OR CONTAINED IN ANY DBFL SPECIFICATIONS OR DRAWINGS UNLESS THE EXPRESS CONSENT HAS BEEN OBTAINED IN ADVANCE, IN WRITING, FROM DBFL.

NOTES:

- THIS DRAWING IS TO BE READ IN CONJUNCTION WITH ALL RELEVANT ARCHITECTS AND ENGINEERS DRAWINGS AND SPECIFICATIONS.
- ALL EXCAVATIONS FOR FOUNDATIONS TO BE INSPECTED BY A CHARTERED REGISTERED PROFESSIONAL AT CONSTRUCTION STAGE.
- FOUNDATION WIDTHS AND DEPTH WILL VARY TO SUIT GROUND CONDITIONS ON SITE AS THEY ARE ENCOUNTERED DURING CONSTRUCTION AND SUBJECT TO DETAILED DESIGN.

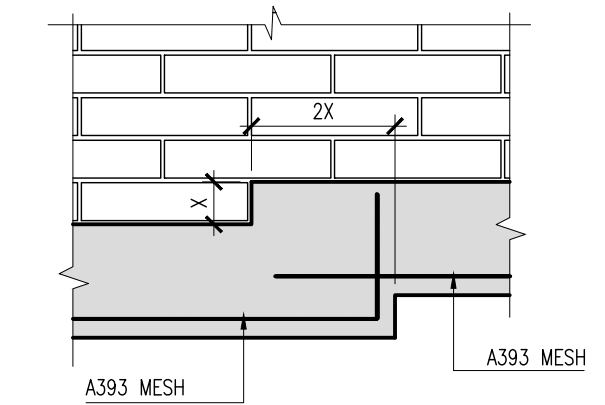

TYPICAL FOUNDATION STEP DETAIL (1:20)

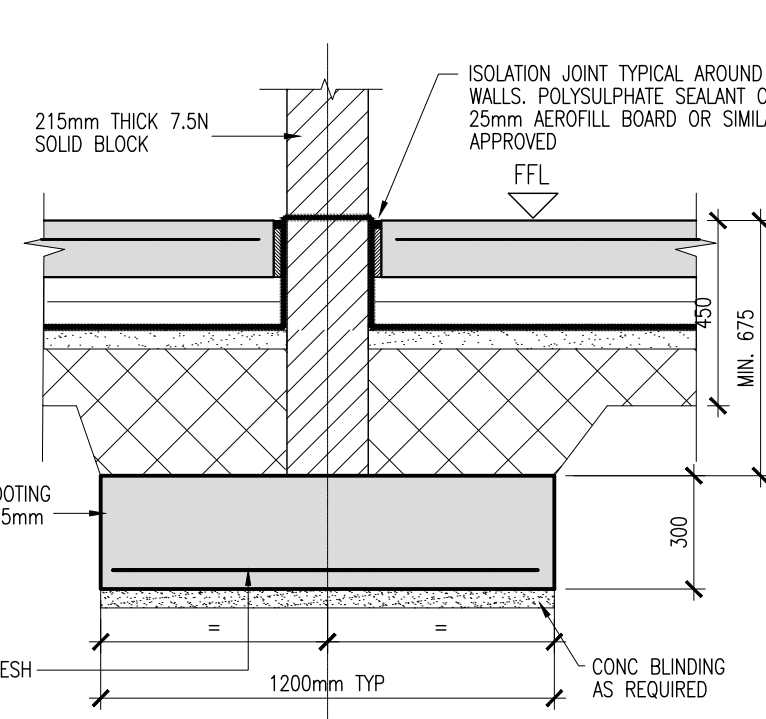

TYPICAL HOUSE FOUNDATION DETAIL 2 (1:20)

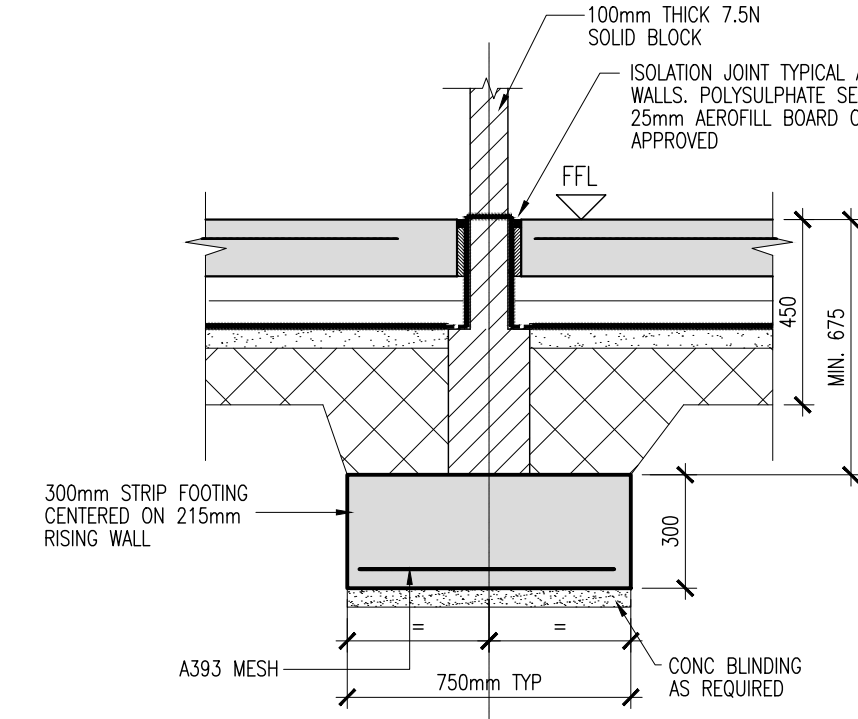

TYPICAL HOUSE FOUNDATION DETAIL 3 (1:20)

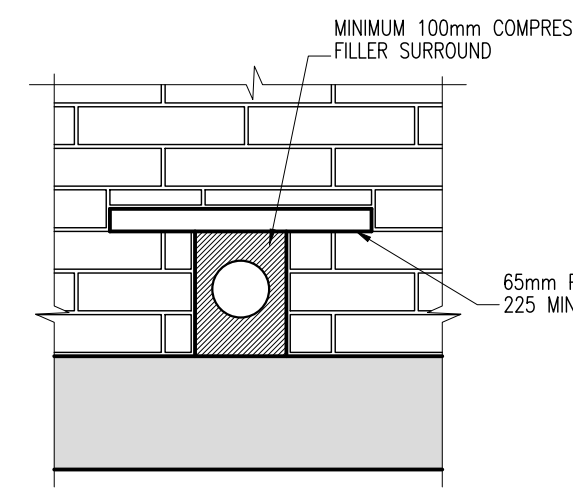

SERVICES ABOVE FOUNDATIONS (1:20)

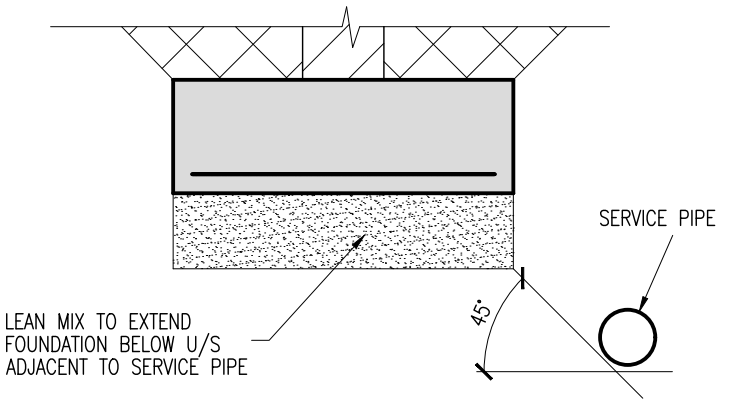

SERVICES ADJACENT TO FOUNDATIONS (1:20)

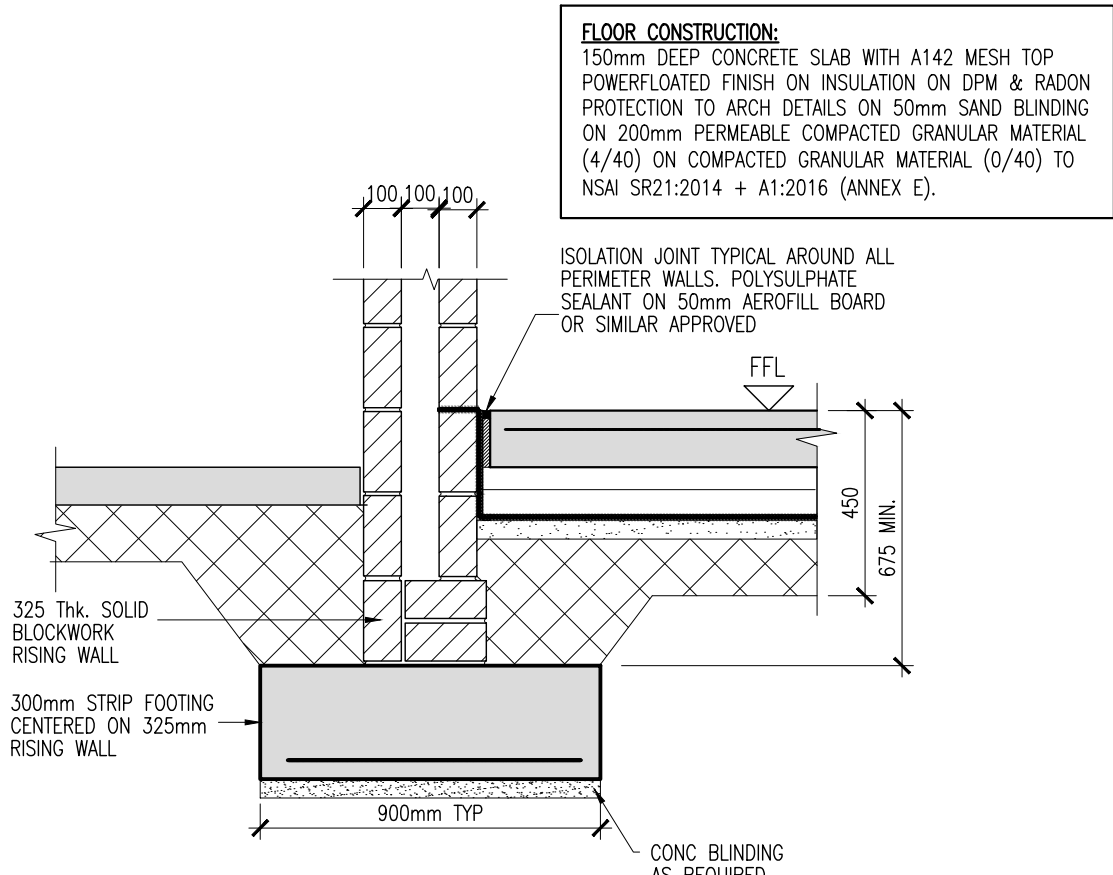

TYPICAL HOUSE FOUNDATION DETAIL 1 (1:20)

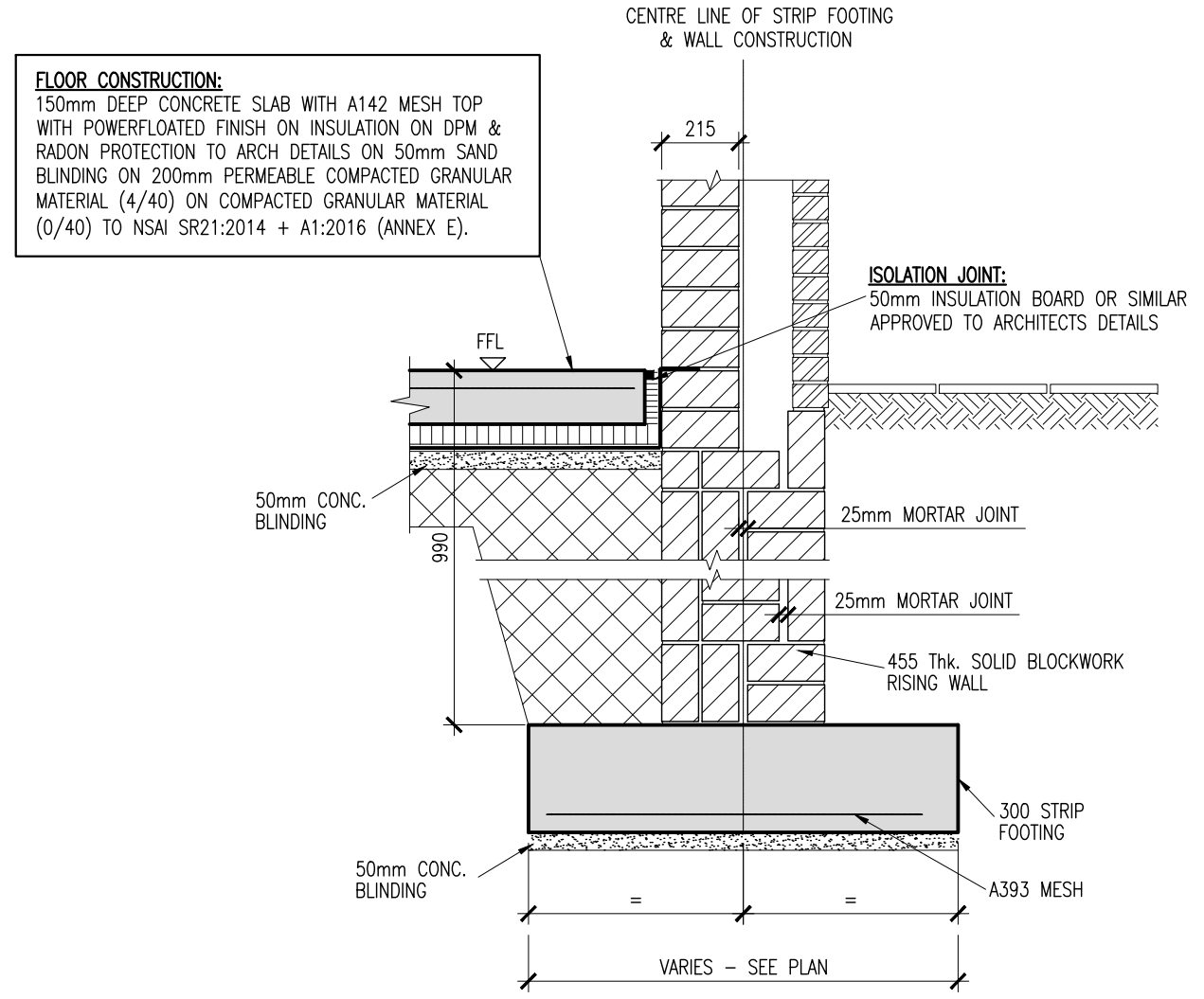

TYPICAL APARTMENT FOUNDATION SECTION 1 (1:20)

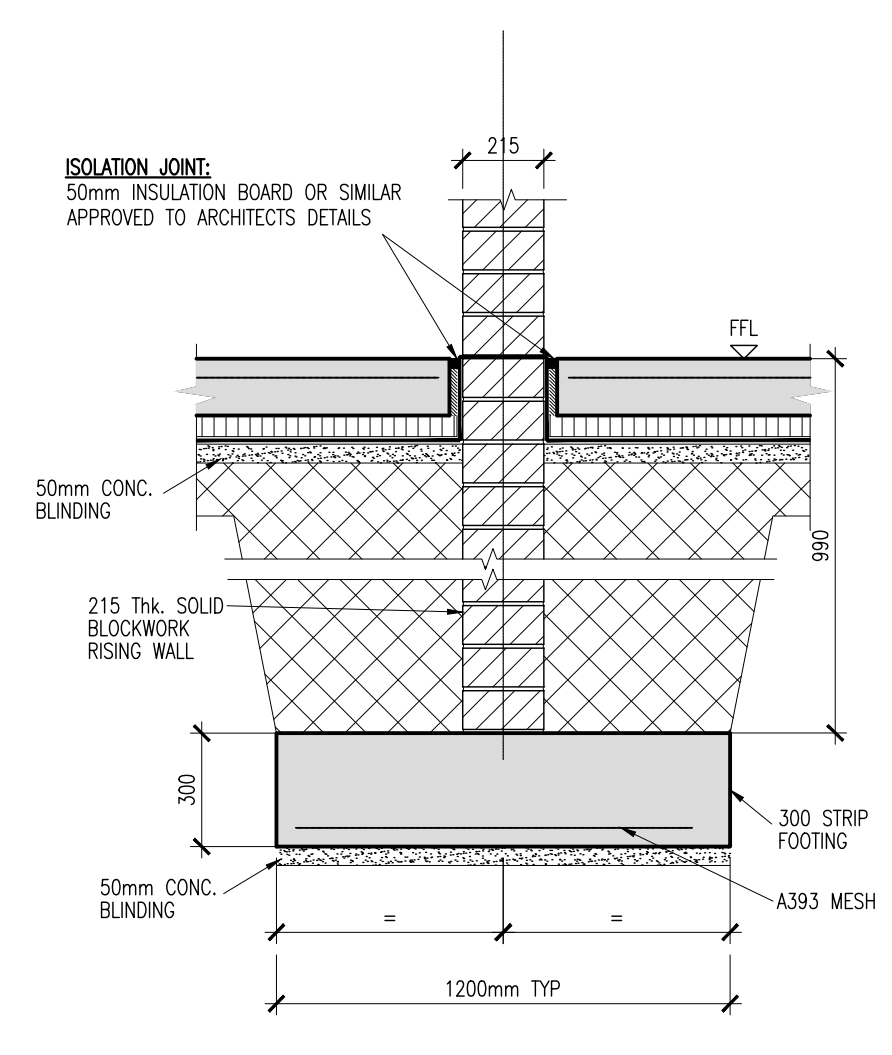

TYPICAL APARTMENT FOUNDATION SECTION 2 (1:20)

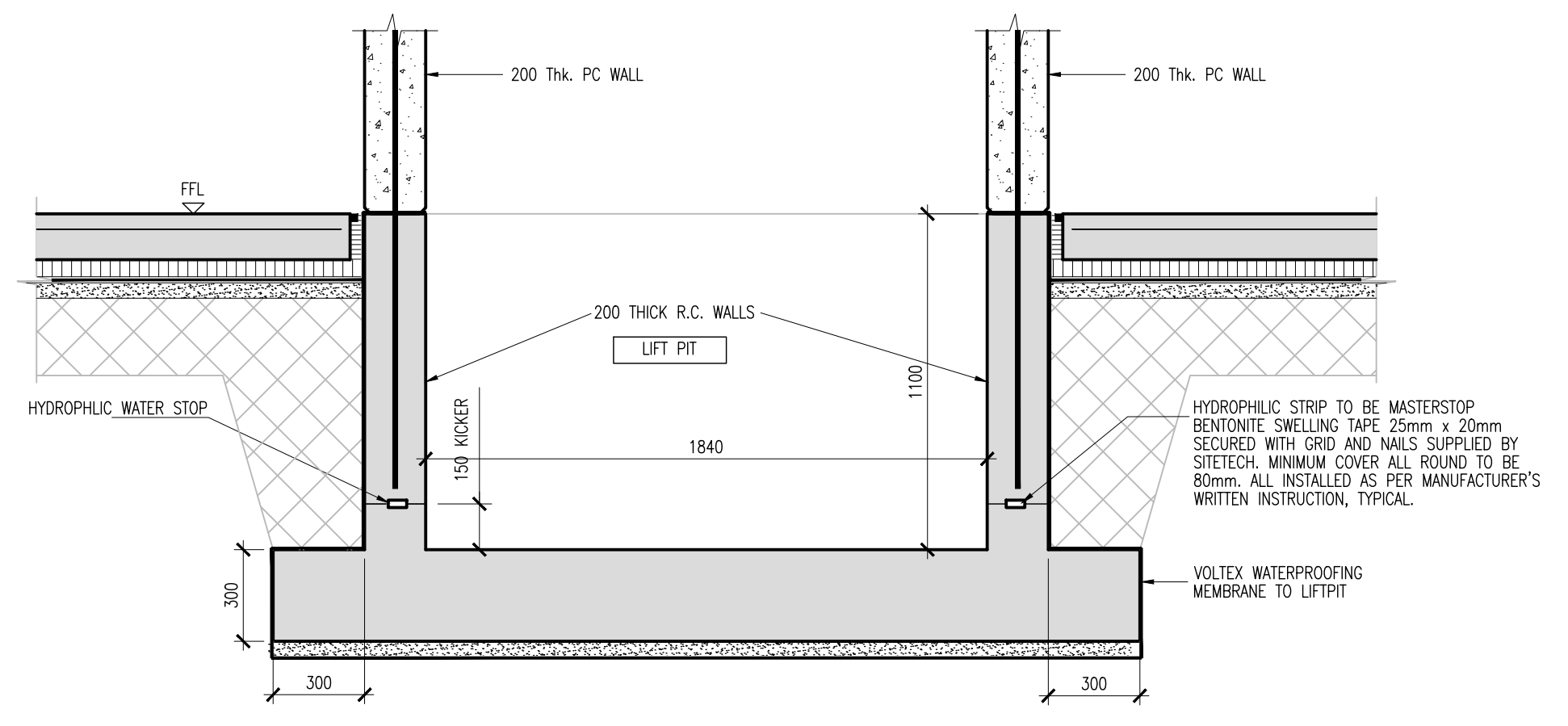

TYPICAL APARTMENT FOUNDATION SECTION 3 (1:20)

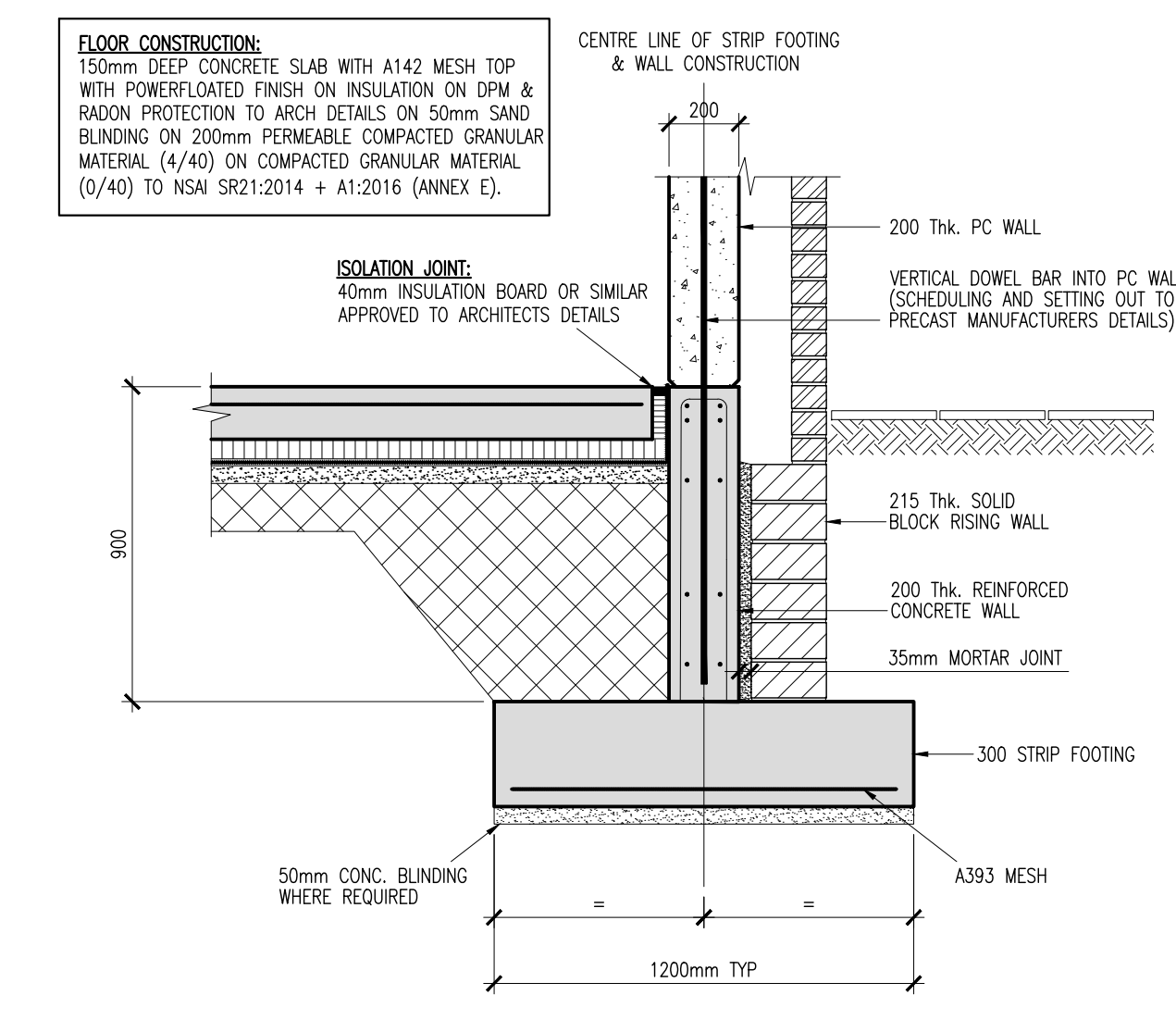

TYPICAL APARTMENT FOUNDATION SECTION 5 (1:20)

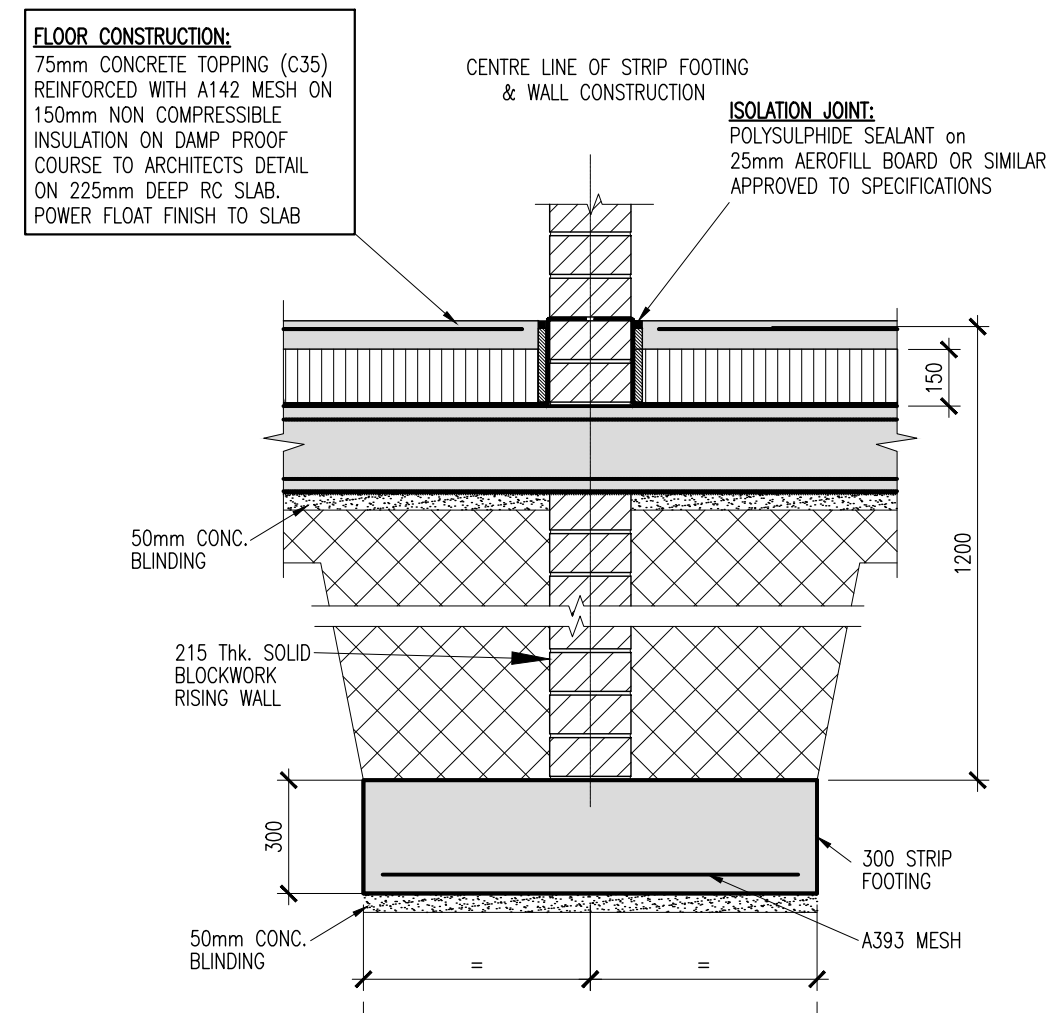

TYPICAL APARTMENT FOUNDATION SECTION 6 (1:20)

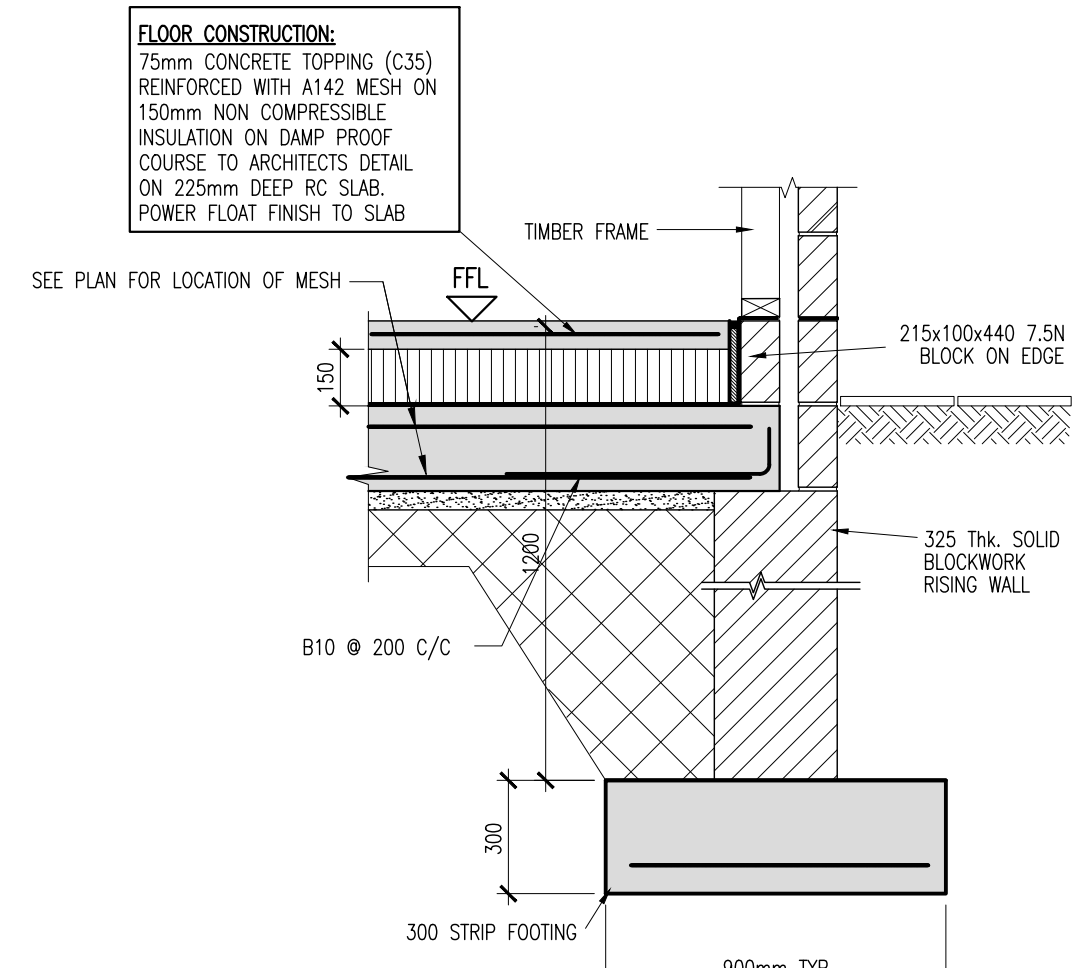

TYPICAL APARTMENT FOUNDATION SECTION 7 (1:20)

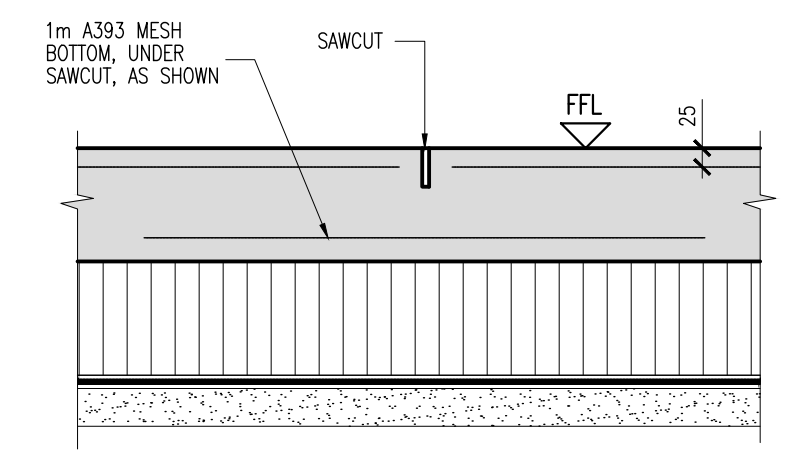

SAWCUT DETAIL (CJ)
(Scale 1:10)

ORDNANCE SURVEY IRELAND LICENCE
No EN 0017922
© ORDNANCE SURVEY IRELAND
GOVERNMENT OF IRELAND

P01	13/06/22	STAGE 3 SHD	PJC	NGC
rev	date	description	by	chkd.
		A - Approved		
		B - Approved with comments		
		C - Do not use		

S2 - INFORMATION PLANNING

DBFL Consulting Engineers
Civil, Structural & Transportation Engineering
www.dbfl.ie

DUBLIN OFFICE: Ormond House, Upper Ormond Quay, Dublin 7, D07 W704
PHONE: +353 1 404 4000
CORK OFFICE: 14 South Mall, Cork, T12 CT91
PHONE: +353 21 2024538
WATERFORD OFFICE: Suite 10 The Atrium, Maritime Gate, Canada Street, Waterford, X91 W028
PHONE: +353 51 309 500

project ref. **NEWCASTLE SOUTH**

drawing title **TYPICAL FOUNDATION DETAILS SHEET 2**

client **CAIRN HOMES PROPERTIES LTD**

designed by	author	scale	sheet size
NGC	IC	AS SHOWN	A1
drawing no.		revision	
210026-DBFL-RD-SP-DR-C-5105		P01	